

Insight Consulting

insight*CON*

game changing insights and executions







insight⁷con

SAVE UPTO 40% ON YOUR DIESEL BILLS

INTRODUCING CUTTING EDGE & INNOVATIVE
POWER SOLUTION TO SAVE YOUR MONEY



Contents

• Background	01
• Our Infrastructure	02
• Our Approach to Procurement Management	03
• Procurement of Energy	04
• Procurement of IT	05
• Clients	06
• Solar & Renewable Energy	07
• Our Commitment	08
• Partners in Progress	09
• Environmental Benefits	10
• Major Application of Renewable Energy	11
• Solar Power System Working Flow	14
• Solar Power System	15
• Solar Tubewell	16
• Cutting Edge Backup Power System	17
• Allspark Basic System & Main Functions	18
• Insight Consulting CCTV	21
• Fire & Safety	23
• KCC Paints	24
• Elevators	25
• Recommendation Letters	26
• Ethics Code for Employees of Insight Consulting	41
• School Tracking System	43
• Insight Consulting Customer Care	48





BACKGROUND

1. Started in 2002
2. FY 13 turnover \$ 4.56 million
3. Core competency
 - a. Consulting
 - b. Procurement
 - c. Process engineering
4. Head office Karachi
5. Number of employees 70
6. Gst registered

OUR INFRASTRUCTURE

insight⁷con



Builtup area of more than 5000 sq. ft. which has been divided into 6 major departments. Located at the central business area of the city. Entire premises including Entrance, Reception & other area are monitoring by CCTV camera. Door Access System & Biometric System are installed for security purpose. Dedicated internet high speed line. Customer support - Online, Email, Phone calls & with help of Team Viewer. Workplace is complete with all support services & activities.

OUR APPROACH TO PROCUREMENT MANAGEMENT

When supply cost pressures increase, so does the opportunity to gain an important source of untapped margin. By taking a more comprehensive approach to what we buy and how we buy it, companies can free up cash and refocus resources to fun strategic priorities without the pain of layoffs. A comprehensive approach means deploying a broader set of tools to better negotiate prices or becoming more efficient at using supplies. It also means getting full organizational alignment resuring that roles, decision rights & incentives all work toward the goal of lowering procurement costs.





PROCUREMENT OF ENERGY

1. Insight Consulting procures following items for its clients in energy sector
 - a. Generators
 - b. Solar power
 - c. Fuels
 - d. Lubricants



PROCUREMENT OF IT

1. Insight Consulting procures following items for its clients
 - a. Desktop software
 - b. Hardware
 - c. Mobile software
 - d. Point of sale software
 - e. Point of sale hardware





CLIENTS

SOLAR & RENEWABLE ENERGY



OUR COMMITMENT

Our Commitment to Renewable Energy

With massive rise in fossil fuel, electric tariffs & load shedding the only real salvation is in use of renewable energy resources. Solar is the solution to have a safe future without any dependencies.

Insight Consulting is a leading renewable energy provider. It provides end to end turn key solutions for energy system design and integration services. Insight Consulting has recently launched its operations in Pakistan market to introduce the benefits of renewable energy technologies to our customers & assist them in use of clean, for free renewable energy solutions to meet the ever growing demand for electricity.

Company Vision

We are sure that it won't be much longer until all the energy we need to live on earth will be produced cleanly & decentralized & be shared fairly. To turn the energy supply system around, all efforts must aim to grow the renewables.

We consider ourselves a part of the global network shaping this transformation.

Our Services

We provide services starting from the enquiry all the way for commissioning of the system. All services performed by Insight Consulting are 100 percent guaranteed.



PARTNERS IN PROGRESS

Our Experience to Serve You



- More bank client choose insight consulting than any other clean energy company.
- Our 100 employees are dedicated to serving our customers.
- On an average day, we help a new family go solar every 5 minutes.

We Do Great Work



- We are skilled & knowledgeable thorough professionals who build systems to last.
- Our house engineering team will custom design your system.
- We select only the best in class, high quality panels, equipment & hardware.
- Safety is important to us. We will keep your home, your family & our crew safe.

We Lower Your Energy Costs



- We offer a cleaner, more affordable alternative to your utility bill.
- We constantly innovate better ways to achieve clean energy savings.
- We know that the customers wants a better cleaner, cheaper electricity & we don't believe you to make compromises to get it.
- We guarantee our quote price per kwh, it will not change throughout the project.

We Make it Simple



- Our Customer Care team will manage your project from start to end, including engineering design, installation, rebate applications & ongoing support.
- Your online account has been upto date like : your project status & customer resources.
- Insight Consulting shows us how to perform at a glance & allow insight consulting to respond if needed.

We Partner for the Long Term



- By looking holistically at both your gas & electricity usage, we can save you more money by using less energy with our energy vehicle chargers.
- A third of our new business comes from satisfied customers.

ENVIRONMENTAL BENEFITS

We believe individual energy choices have a direct impact on the environment and together we can make a real difference.

Your system will offset 192,953 lbs. of CO₂, saving the equivalent of

Save more with other clean energy products



Driving a Car
207, 234 Miles



Home Energy Evaluation

A comprehensive audit will also diagnose the causes of energy loss & prioritize improvements with greatest impact.



CO₂ Absorbed
by 104 Trees



Energy Improvements

We advise to implement energy upgrades to heating, air conditioning, insulation, water heaters & more.



Gallons of water used
to make electricity



Energy Vehicle Chargers

We also install electric vehicle charging systems which are compatible with all EV's. Combined with solar power, you can drive on sunshine!



MAJOR APPLICATIONS OF RENEWABLE ENERGY

Commercial



We provide solutions to Software Houses, Office, Buildings, Shopping Malls and Billboards so they can take the stress off from the energy crises & focus on their primary business.

Telecommunication



Insight Consulting provides major applications of renewable energy in telecommunication sector is for electrocution of rural located base station & microwave repeaters.

Industrial



Insight Consulting is focused in providing solutions to oil industries starting from small projects to all the way of mega projects. Textile, Pharmaceutical, Dairy, Sports, Live Stock & Telecommunication are the primary focus.



Urban Development

Insight Consulting plays a vital role in urban development by providing solar based Street Lights, Traffic Signals, Parking Lots lights & aviation lights.



IPP

If you are looking to become an Independent Power Producer & sell electricity to the government of Pakistan, Insight Consulting can provide all the services starting from design all the way to commissioning.



Agriculture

We provide solutions to the agricultural sector all around Pakistan: Solar Water Pumps, Solar Farm Lights & Solar Tube Wells.

MAJOR APPLICATIONS OF RENEWABLE ENERGY



Medical Facility

Renewable energy could be the source of primary/alternate power generation of the entire medical facility.

MAJOR APPLICATIONS OF RENEWABLE ENERGY



Rural Electrification

Working with governmental & nongovernmental organizations (NGO), Insight Consulting will bring electrical power to rural and remote areas. Besides the obvious benefit that electricity will bring to daily lives of villagers, more importantly the reliable electrical supply will enable them to improve their economic condition.

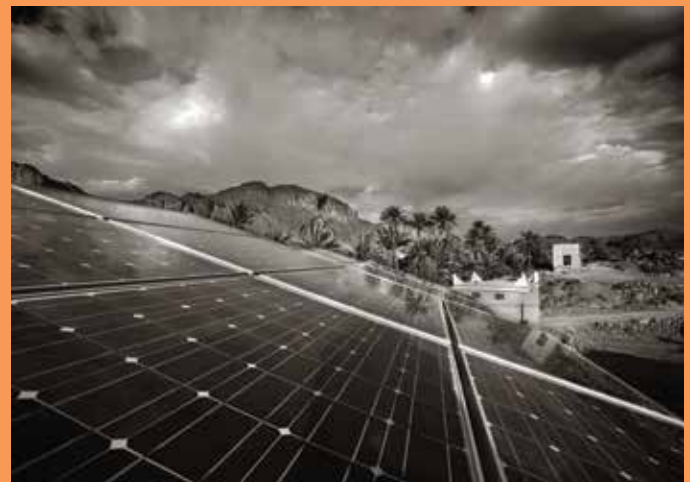

SOLAR POWER SYSTEM WORKING FLOW

- F** Fuse
- H** AC Hot
- N** AC Neutral
- G** AC Ground

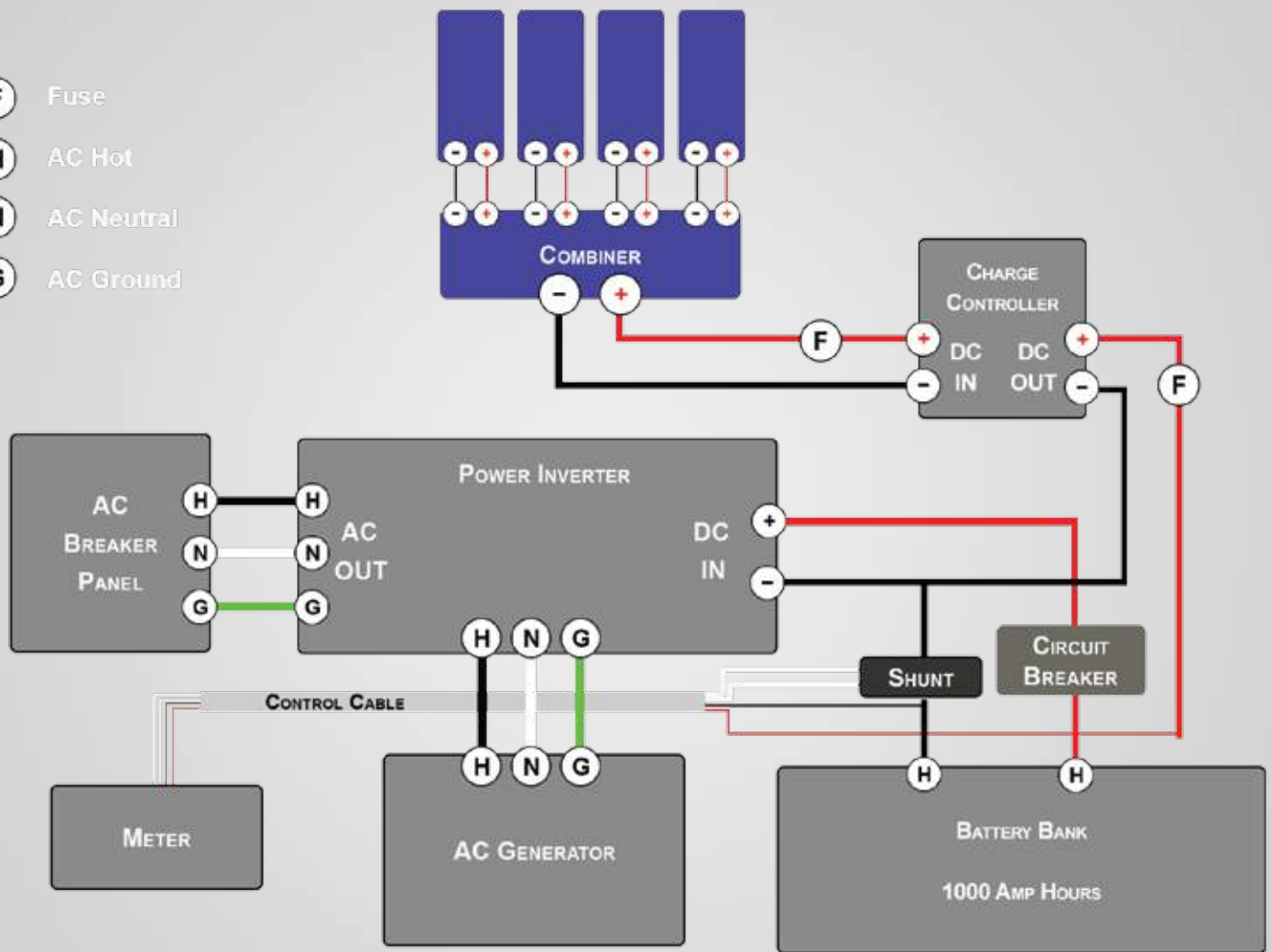

SOLAR POWER SYSTEM



SOLAR TUBEWELL

Specifications

Why we use Solar Tubewell System

Our submersible tube well systems are designed to be used in a variety of applications in rural & urban areas. Some of the potential applications are in drip irrigation, livestock watering, watering the cultivated area etc.

What are the advantages of solar tubewell systems?

Solar tube well in Pakistan is the best combination of utility and efficiency. Following are some of the advantages of using our solar tube well systems:

- Zero Running costs of the systems
- Our solar tube wells require No maintenance
- No Electricity Bill!
- No need to pay for fuel costs or deal with fuel spills
- Solar tube wells are easy to install
- Solar tube wells are simple & reliable
- Unattended operation of our solar tube wells means that you are free for other tasks

In addition to above points, solar tube well in Pakistan are the most economical solution for all water pumping needs of all sectors of the economy. Solar tube well use solar power panels to run solar pump.

Configuration of Solar Tubewell Systems

Solar pumps in a wide range of configurations for various domestic, farming & agricultural applications. Our experts take into account all your needs & then recommend a solar pump configuration that best suits your needs. Please note that these Solar Tubewells work at all depths from 10 to 600 feet. All the systems employ pumps made by Insight Group Holdings.



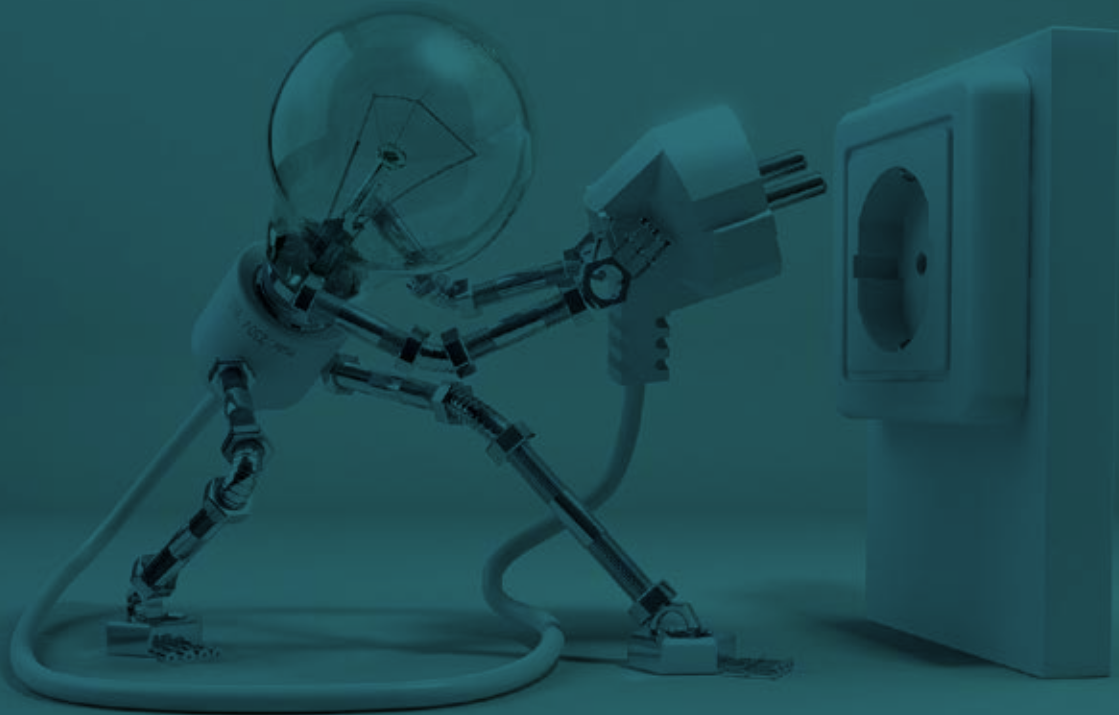

ALLSPARK UPS BASICS SYSTEM & MAIN FUNCTIONS

General Introduction

The Allspark UPS Backup solution for home, bank, Office & Industries without a Solar Panel system. The Allspark UPS will be charged with grid (Electricity) only.

The Allspark UPS system gives long backup upto 8hrs to 10hrs. With the Powerwave 1000's front access panel, replacing battery pack which no longer requires the critical load to be interrupted, ensuring you are always protected 24/7.

The continuous supply of power is critical to commercial & industrial process installations. A power failure, or even minor disturbances in the power supply, will interrupt the process chain & eventually result in system shutdown. This could cause substantial financial losses or even jeopardize the safety of human lives.

The key function of Allspark UPS systems is therefore the protection of electrical power supplies to installations (also called consumers or loads), which cannot tolerate even the slightest voltage interruption or inconsistencies. Unfiltered electrical power supplied by utilities may contain harmonics, sags, spikes or noise. Introducing one or more Allspark UPS systems along the power supply chain will effectively eliminate these disturbances.

Most importantly, during power failure conditions, the Allspark UPS will bridge the critical power supply gap. In these instances, the system automatically switches to large battery banks to draw the required electrical power until mains is again available. This occurs without affecting the load performance. The size of the battery banks & eventual alternative power source (bypass, diesel power generator), depend on battery configuration.

Allspark UPS systems are often installed to support the safe shutdown & reboot of critical process installations. Modern Allspark UPS systems provide auxiliary functions such as automatic monitoring, system performance testing & alarm display.

INTRODUCING
PAKISTAN'S
FIRST LONG BACKUP UPS UPTO
8 HOURS





Major Benefits

- Event log of all activities affecting the battery bank.
- Remote access - via TCPIP or Modbus.
- Automatic capture of data & report generation.
- Individual UPS impedance measure.
- Optical isolation for increased safety.
- Individual & ambient battery temperature measure.
- Individual & battery string voltage & current measure.
- Compatible also with Ni-Cd & Lead batteries, open or recombination types.
- Wide choice of configurations to meet one of the most complex architectures.
- It also reduces maintenance costs through preventive maintenance instead of emergency replacement.
- It has maximized battery life through smart diagnostics, regular data analysis & on time remedial action.
- It increases its safety on the site as backup power remains always available & less human presence is required in the battery room.

THE BEST ALLSPARK UPS SYSTEM IN PAKISTAN



Allspark UPS Bank Backup

Applications

- This emergency Backup Power System is a must have during electricity unstable, load shedding & other natural disasters!
- If managed carefully, this system will run for days while powering up your:
 - Lighting
 - Cell phones
 - Well pump
 - Refrigerator
 - Internet
 - Security alarm

Seamless Electrical Coverage

- This 240-volt backup power unit incorporates an inverter that monitors the grid for disruptions. When the grid goes down or is disconnected, the inverter switches to battery backup in less than a milli second, (because Allspark design as an online architecture) keeping your critical loads online until the grid comes back.

Major Benefits

- Stop getting left in the dark! Simply install the Battery Bank Backup System & you are ready to go when the utility grid is knocked out or unstable.

INSIGHT CONSULTING

CCTV



CCTV BROCHURE

Insight CCTV

 45 G, First Floor, PECHS, Block 6, Karachi.

 021-34558183

 insae@insight.pk

 www.insight.pk



DOME CAMERAS



Digital Video Recorder



Color Cameras



PTZ CAMERAS



RFID Access Control



Magnet Door Lock



NETWORK CAMERAS



Camera Controller



Access Control & Time Attendance



ANALOG CAMERAS



Network PTZ Camera



Fixed Dome Cameras

SECURITY

SOLUTIONS

SECURITY

SOLUTIONS

CCTV Software



Secure Your Home & Business



Fire & Safety

Insight Consulting is specialising in trading and installation of fire fighting, safety and security equipment, systems and services maintaining a wide range. We can proudly claim to be one of the best in this field in Pakistan with most professionally trained team in the industry.

Services

At Insight Consulting we offer a wide range of fire & safety services to meet your specific need, all backed by trained professionals. Our range of services include; Servicing & Maintenance of Fire Equipments, Fire Health & Safety audits

Our Mission

To provide complete solutions in fire prevention, protection, security and occupational health and environmental safety, to all industry sectors, which are committed to the latest technology and high quality products, services and utilizing a team of professional expertise in Pakistan.





KCC Paints

Insight Consulting exclusively represent KCC for their entire product range covering paints and construction products. The Major areas of focus in the Paints Business are Heavy Duty, Refinish and Decorative Paints. Insight Consulting in a very short span of time has developed a long list of reputable customers including MNC's in the industrial and OEM sectors. Insight Consulting is also at out set of setting pre-treatment business.

Chemicals

In the Chemicals Business Insight Consulting focus on a agency relationships with renowned International suppliers. At the same time Insight Consulting have developed a product portfolio consisting of select general and specialty chemicals targeted at the major industrial sectors of the country like sugar, plastic, petroleum, ethanol, textile and others .



Indent & Bulk Commodities

Bulks Business is the major contributor of Insight Consulting turnover and profits. Indent business of cement Clinker, mil scales, Chromium and ethanol of distillers other than group are major area of business. The business is actively pursuing developments in the Metals, Seeds, and food sectors.





Elevators

Insight Consulting is one of the world's leading elevator companies. As a step up in vertical integration based on the concerns of quality, cost, and supply time Insight Consulting established this service. Insight Consulting strived in its pursuit of delivering a quality product maximizing customer satisfaction in every possible way. It provides its customers with industry leading elevators and with innovative solutions for their maintenance and modernization.

Standard VVVF Control Panel

We also hold expertise in manufacturing of Standard or DOL (Direct On Line) controllers that meet application demands in the Elevator industries. These are specially made for elevators and feature swift operating system with 5 Hp motor that delivers in them clear digital indications. Further, these controllers also have minimum maintenance requirements during working.



Our Mission

We shall provide total customer satisfaction and achieve leadership in chosen markets, products and services across the globe, through excellence in technology, based on research and development. We will invent, develop and successfully market elevator products to prevent more efficient, affordable and right value to our customers. We Determine to provide better quality.





- Excellent
- Good
- Average

RECOMMENDATION LETTERS



Dubai Islamic Bank
Pakistan Ltd.



بنك دبي الإسلامي
بنك دبي الإسلامي

Dated: 22nd July, 2014

Dubai Islamic Bank

To whom it may concern

This is to certify that Insight Group is an authorized outsourcing, procurement and sourcing management consulting firm for Dubai Islamic Bank. Furthermore, Insight Group is authorized, on behalf of Dubai Islamic Bank, to manage procurement of diesel fuel on transportation of fuel.

Thank You.

M. Asadullah Khan
021-35360034-39 (8731)

Registered Office:
Hassan Chambers, DC-7, Block-T, Kolkastan Clifton, Karachi, Pakistan.
PABX: (+9221) 36360039

www.dibpak.com



Dated: 16th November, 2012

To whom it may concern:

This is to certify that Insight Group is an authorized outsourcing, procurement and sourcing management consulting firm for Faysal Bank. Furthermore, Insight Group is authorized, on behalf of Faysal Bank, to manage procurement of diesel fuel on nationwide basis, manage fuel payments, monitoring and coordinate transportation of fuel.

Thank you.

A handwritten signature in black ink, appearing to read "Habibullah Shah".

Habibullah Shah
Faysal Bank
021-32799148



Soneri Bank

Dated: August 7, 2014

To whom it may concern

This is to certify that Insight Group is an authorized outsourcing, procurement and sourcing management consulting firm for Soneri bank Limited. Furthermore, Insight Group is authorized, on behalf of SBL, to manage procurement of diesel fuel on nationwide basis, manage fuel payments, monitoring and coordinate transportation of fuel.

Thank you



Faraz Ameer

Vendor Management Unit

Ph: 021-111-567-890 Ext: 2959

Cell: 0300-3822010

Soneri Bank Limited, Al-Rahim Tower, I.I. Chundrigar Road, P.O. Box No. 5856, Karachi, Pakistan.
Tel: 32444401-05 & 111-567-890, Fax: 32444734, Swift: SONEPKA000, Website: www.soneribank.com



U Microfinance Bank Ltd

29-Apr-14

Insight Group
45 G, 1st Floor
P.E.C.H.S Block 6, Karachi

Dear Ms. Nabeela,

I am writing to recommend the services of the Insight Group Service on behalf of U Microfinance Bank Ltd. We have been using Insight Group Services for the past 1 year, and have always been completely satisfied. They do an excellent job, are always punctual, and offer the most competitive rates.

They have been very reasonably priced, and have done exactly what we've asked of them.

I'm happy to recommend the services of Insight Group.

Salman Khan
Manager HR & Admin
U Microfinance Bank Ltd



Head Office:
Eastern Hall, Razia Sharif Plaza,
Jinnah Avenue, Blue Area, Islamabad.
UAN: 111-182-265,
Website: www.ubank.com.pk

Providing Transaction Convenience Through Touchpoint



To Whom It May Concern

This is to certify that Insight Group is an authorized fuel providing company to the TouchPoint (Pvt) Limited.

Furthermore, Insight Group is also authorized on behalf of TouchPoint (Pvt) Limited, to manage procurement of diesel fuel and coordinate transportation of fuel we well.

They are engaged with us since last two years and providing professional services at an excellent level of satisfaction.

8/6/14

Manager Admin

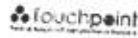

DEBOLD

Cell: 0334 - 0360822
☎ +92 21 - 3438 8900
☎ +92 21 - 3430 3351-2
Fax: +92 21 - 3455 3458
78-R, Block-II, PECHS, Karachi-75400

Dated: 8th August, 2014



Admin/33/PG
12/07/2014

TO WHOM IT MAY CONCERN

This is to certify that Insight Group is authorised on behalf of Medicenter General Hospital to manage procurement of diesel fuel, monitor and coordinate its transportation to the Hospital premises.



TANWEER ANSARI
(Administrator)

78/L, Block-2, Ghazali Road, P.E.C.H.S., Karachi-75400
Tel : (+92 21) 34315651-54 Fax : (+92 21) 34558308
E-mail: medicenter81@hotmail.com
medicenter_hospital@yahoo.com

RECOMMENDATION LETTERS





BankIslami

BankIslami Pakistan Limited
 11th Floor, Executive Tower, DeLam City,
 Marine Drive, Block-4, Clifton, Karachi.
 Tel: (92-21) 111-2478879-111
 Fax: 25278172
 www.bankislami.com.pk

Head Of Administration,
 Dubai Islamic Bank,
 Kareem Chamber, 3rd Floor,
 1.I.Chundrigar Road,
 Karachi.

Dear Sir,

Subject: Inquiry about vendor

REF# ADMIN/GSD/VENDOR
 DATED: October 22, 2014

M/S INSIGHT GROUP has applied for being an "Approved Vendor" at BIPL. They have mentioned your name as their client. The vendor claims that they has been working since many years and has a good reputation in market. They also claims that they has never been black listed in any Government, semi Government or private organization.

As we are in process of taking decision about the captioned vendor, we request you to kindly give us your views for the following:

S. #	Query	Excellent	Good	Satisfactory	poor
1	Quality of product		✓		
2	Products / services rate as compared to local market	✓			
3	Consistency / stability in rates		✓		
4	Delivery time (As per terms)		✓		
5	Response to urgent queries / requirements	✓			
6	Credit facility period		✓		
7	Professional ethics & behavior		✓		

We shall be grateful if you provide us your feedback based on the above mentioned queries and return this letter to us duly signed by authorized person in the space given below, in a sealed envelope at your earliest convenience.

We assure you that the information provided will be treated strictly confidential. Your early co-operation in this matter will be highly appreciated.

Sincerely,

[Signature]
 Authorized Signature

[Signature]
 Authorized Signature
 ABDUS SAMAD
 Executive In-charge GSD

AUTHORIZED PERSON
 Signature: *[Signature]*
 Name: *M Asadullah Khan*
 Designation: *Admin head (South)*

Serving you, the Right way

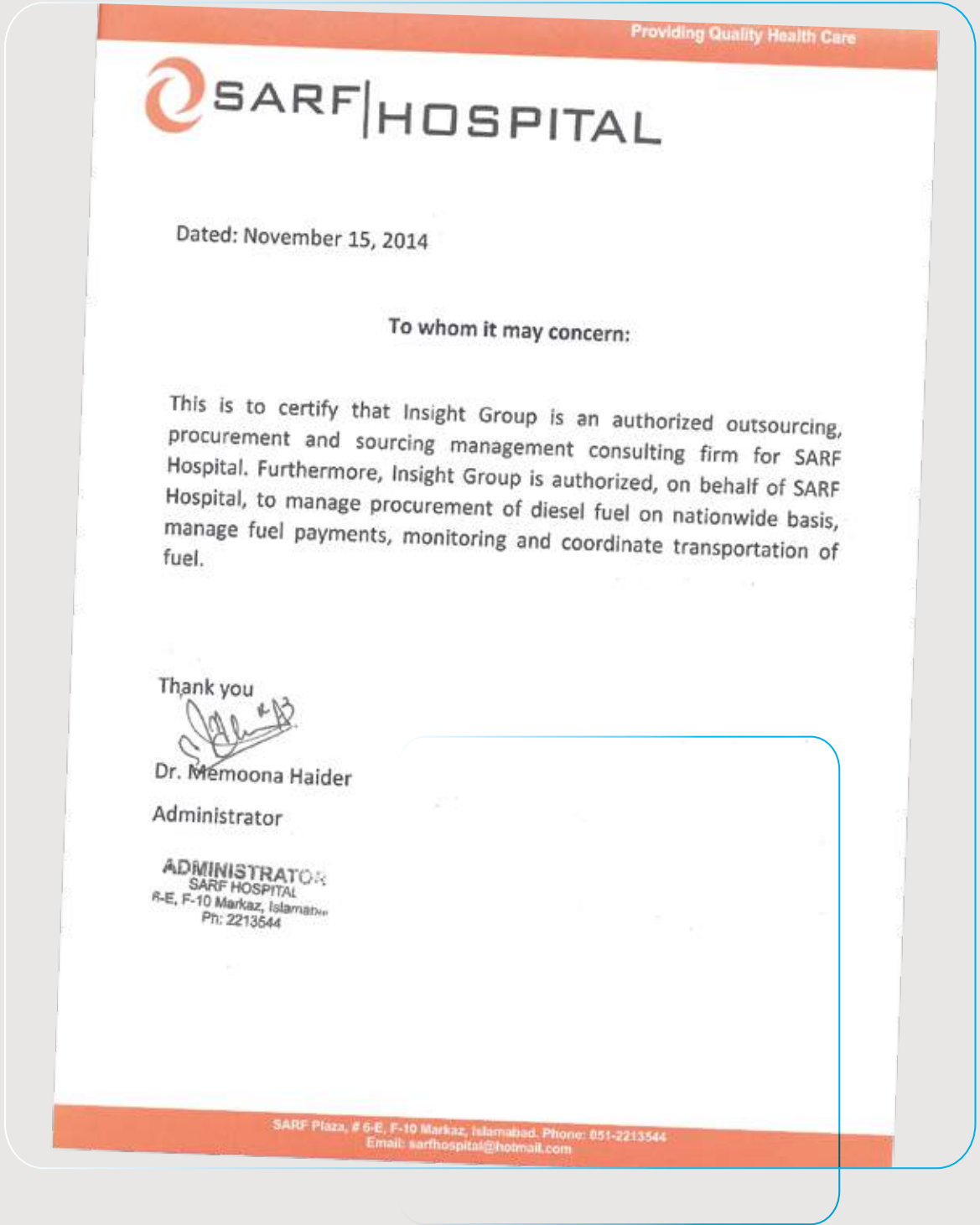

Providing Quality Health Care



Dated: November 15, 2014

To whom it may concern:

This is to certify that Insight Group is an authorized outsourcing, procurement and sourcing management consulting firm for SARF Hospital. Furthermore, Insight Group is authorized, on behalf of SARF Hospital, to manage procurement of diesel fuel on nationwide basis, manage fuel payments, monitoring and coordinate transportation of fuel.

Thank you

Dr. Memoona Haider
Administrator

ADMINISTRATOR
SARF HOSPITAL
6-E, F-10 Markaz, Islamabad
Ph: 2213544

SARF Plaza, # 6-E, F-10 Markaz, Islamabad. Phone: 051-2213544
Email: sarfhospital@hotmail.com



January 16, 2015

To whom it may concern:

This is to certify that M/s Insight Group is an enlisted firm with KASB Bank, in respect of manage procurement of diesel fuel for generators on nationwide basis, manage fuel payments, monitoring and coordinate transportation of fuel.

Thank you



Imran Ausaf
KASB Bank Ltd.

Principal Office: Business & Finance Centre, I.I. Chundrigar Road, Karachi. 74000, Pakistan.
Tel: (PABX) 92-21-32446005-10,32446772-7 UAN: 021-111-555-666, Fax: 92-21-32446828 www.kasb.com



Barclays Bank PLC, Pakistan
Ground Floor,
Dawood Centre, Near PIDC,
M.T, Khan Road,
Karachi - 75530
Pakistan.

UAN: +92 (21) 111-105-555
Fax: +92 (21) 35634050

Dated: 11 August, 2014

Subject: Confirmation of Services by Insight Group

To whom it may concern,

This is to certify that Insight Group is an authorized procurement firm for Barclays Bank. Furthermore, Insight Group is authorized, on behalf of Barclays Bank, to manage procurement of diesel fuel for South region and, manages fuel for all this regional sites.

Yours Faithfully

Mona ARIP
Head of CRES

Insight is a trading name of Barclays Bank PLC and its subsidiaries. Barclays Bank PLC is authorised by the Prudential Regulation Authority and regulated by the Financial Conduct Authority and the Prudential Regulation Authority (Financial Services Register No. 122702). Registered in England. Registered number is 1026187 with registered office at 1 Churchill Place, London E14 5HP.
RUMTH0V018P000117



Main Branch Karachi

February 8, 2012

M/s Insight Group
45-G, 1st Floor,
Block-6, P.E.C.H.S.
Karachi.
Ph: 021-34558181

Dear Sir,

It was very pleased for us to utilize your diesel service with satisfactory backup. We sincerely appreciate your responsiveness and the way you conduct business. We have recommended your company to others because of our satisfaction with your service.

As it is already discussed with you that we are also in need of petrol for our official vehicles which is not in your company's product list. Therefore it is requested to disconnect service from today to onward.

Regards,

Tariq Ahmed Shaikh
Chief Manager

Main Branch: B-9-B-3, Near Post Office Chowrangi, S.I.T.E., Karachi.
Ph # (021) 32587130-32, 32587135-37, 3258144-46 Fax: (021) 32587126 Website: smebank.org

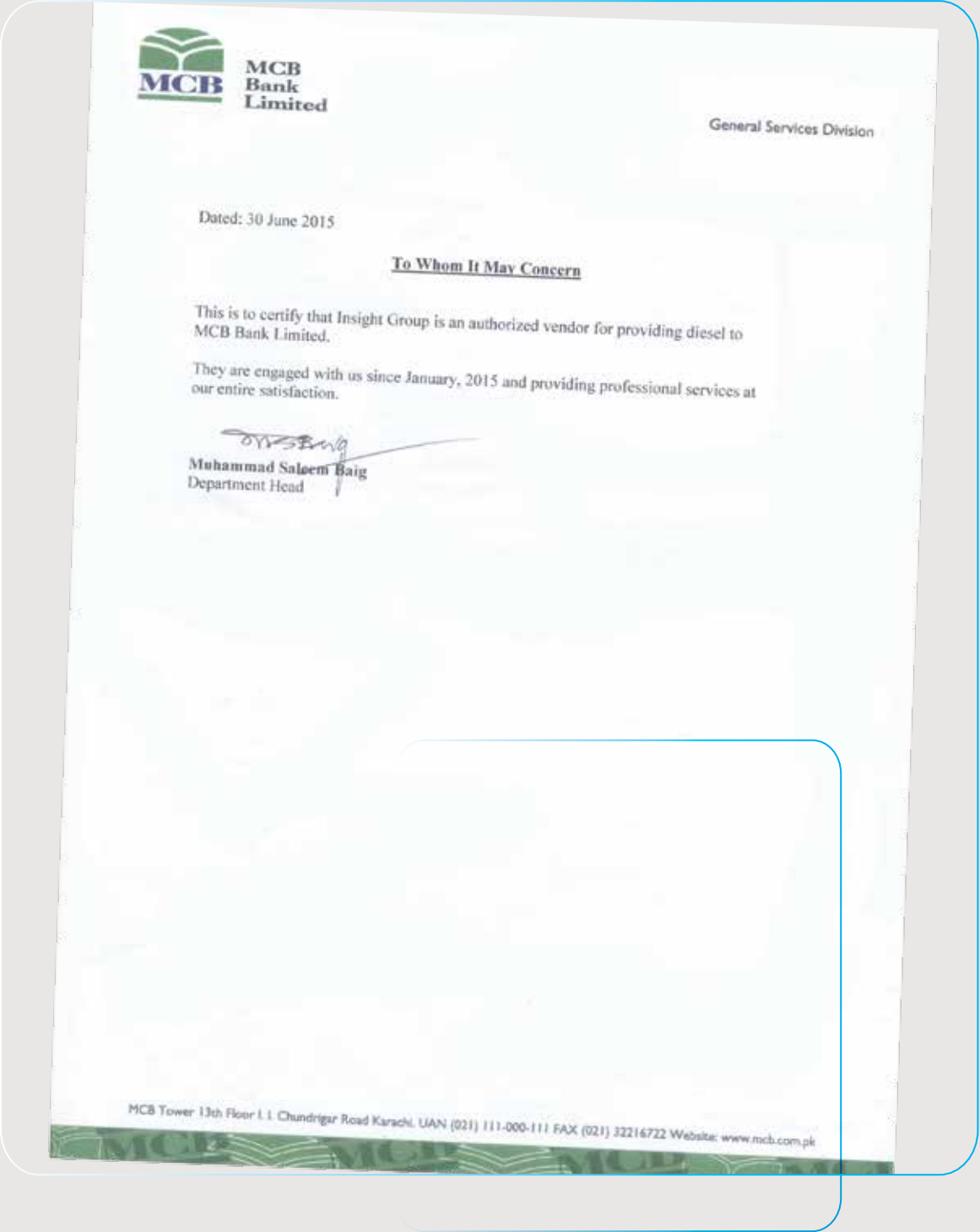

ETHICS CODE FOR EMPLOYEES OF INSIGHT CONSULTING

1. Honesty and transparency

- a. Be honest to the company which has taken care of you in month and years even when the times were tough.
- b. Own up, don't cover up. Get the job done. That is the only thing that matters an counts.
- c. If you are assigned to purchase goods and services for the company, negotiate the best rates, find the best suppliers, go an extra mile.
- d. Do not have any interest dealing in with the suppliers or competition other than official business.



ETHICS CODE FOR EMPLOYEES OF INSIGHT CONSULTING

2. Courtesy
 - a. Professionally attired.
 - b. Hygienically conscious.
 - c. Politeness:
 - i. please and thank you
 - ii. no profanity
3. Work
 - a. Show up on time.
 - b. Work a full shift.
 - c. Strive towards goals.
 - d. Know your job. Do it well. Be confident.
 - e. Cooperate. We are all cracked pots.
4. Improve yourself
 - a. Learn more and new things.
 - b. Work faster, make fewer errors, cause more applause.
 - c. Be a better teammate.
5. Respect others and yourself
 - a. We are equal.
 - b. Communicate clearly, briefly and tone-fully.
 - c. Don't suffer disrespect.
6. Enjoy the day. Have fun.
 - a. Applaud others.
 - b. Be positive.

School **Tracking System**
Safety **Ensured**



Features of the Smart Tracking System for School

Tracks and monitors all school vehicles in real time. Sends auto alerts to parents about actual arrival and departure time of the buses. Parents can log in to access real time information on status of bus locations. Sends auto alerts to parents about pick and drop status of their children.

Auto Alerts

Management gets instant alerts when the Parent school vehicle enters a no go zone or when drivers are involved in unsafe and speedy driving. Contacts between drivers and school management using latest technology. Auto alerts to parents and school management during emergencies and for delays.



GPS & RFID

Busfinder is the GPS enhancement designed for the route finder for pro transportation management solution. It interfaces with your GPS system by displaying bus locations and path points on route finder pro maps so that you can see that your buses where they are supposed to be.





Server for Bus Tracking Records

The system offers both Web & SMS based access to the Central Server so that real time data information about the status of school bus is shared with school principals at any time, so they can keep 24/7 tracking record about their students.

Home Tracking Device

The parent is capable of monitoring the vehicle movement in a user friendly map in real time. The interface will provide the scheduled time of arrival (STA) & the estimated time of arrival (ETA). Any delays from traffic related issues can be identified by looking into the map location.



Confirmation SMS

Enables parents to receive SMS alerts when school bus is within the vicinity of the designated pick up points. Active RFID sends confirmation SMS when the child boards the school bus. Active RFID Sends confirmation SMS when the child alights from the school bus. Enables parents to receive SMS alerts when school bus is within the vicinity of the designated drop off points.





RFID Card

Students swipe an RFID card over a reader installed on the bus, and their name, the date, location and time that they boarded and disembarked the bus is transferred to the school or bus company. Automatic recording of the movements of students including their tracking and monitoring in the school campus is easy with RFID technology. Come any emergency/requirement, they can be reached fast and easy. RFID also facilitates attendance of the teacher.

24/7 Online Tracking

GPS tracking technology is giving parents peace of mind and helping kids stay safe through a program that tracks school buses on their daily routes. The device delivers the data to track your vehicle hosted application, which you can access through our website at any time. You will receive real time vehicle tracking updates including location, speed, direction, idle time, start or stop and more, allowing you to manage a tighter schedule.



Database System

Student information has never been so easy to manage. Quick Schools is an interactive database of student information that is easily accessible and always available for qualified staff. It ensures that administrators will have access to the most recent student info. The database includes basic info about address, sibling names, grades, parents & contact info. This database is linked to all of the student's school classes & activities.





Our System Features

GPS and RFID units install in Bus. Long battery life units with regular data reporting via the GSM/GPRS mobile phone network back to the server. Geo fencing creating multiple user defined zones and boundaries. Creating custom rules associated with vehicles or objects passing into or out of an area or location that may trigger further actions or messages. Issue alerts by SMS, systems messages or email if rules or conditions are triggered such as a zone boundary being crossed by a specific vehicle or object.

Reporting

View object movements in real time by configurable tables or through on screen apping with different icons for each object class. Real time position reporting.



Notifications

Automatic arrival and departure notification with date or time stamp. Snail trails and journey reports. The system supports combined GPS and RFID reporting knowing where your vehicle is and what road it's on. Route history log and reports including downloads to MS Excel Spreadsheets for further analysis."



INSIGHT CONSULTING CUSTOMER CARE



helpdesk@insight.pk

02132000814, 02135432447, 02135432446,
02134558181- 83 0301 8237900



Head Office: 45-G, 1st Floor, Block-6, P.E.C.H.S, Karachi
P: 021-34558181-83, **E:** ifrahim@gmail.com, ifrahim@insight.pk

Lahore Office: 94E St-3, Super Town, Defence Mor, Lahore
P: 042-37029642, **E:** ifrahim@gmail.com, ifrahim@insight.pk

insight⁷CON

game changing insights and executions